

# RACK AND CABINET PRODUCT

Internet Data Center (IDC) Series



## APPLICATION

Widely applied in Finance, Securities and Data Centre and adopted by professional servers' network providers, as IBM, SUN, HP, COMPAQ, DELL, etc .

## MATERIALS

Electro-galvanized Cold-rolled steel sheet. Thickness for frame 2.0mm, mounting rail 2.0mm, side panel 1.5mm, fixed shelf 1.5mm

## STANDARD

Comply with ANSI/EIARS-310-D, BS 5954, DIN41491;PART1, IEC60297-2, DIN41494;PART7,GB/T3047.2-92 standard. Compatible with metric, ETSI and 19 inch international standard.

## FEATURE

- Surface finish: degreasing, pickling, phosphoric, powder coating .  
The thickness of powder coating is 80µm-100µm.
- Curved perforated front door and double-section rear door enable equipment protection, reliable operation with ventilation rate above 80%.
- Double-section side panels, each panel can be easily assembled separately.
- Top and bottom wiring channel can be closed and adjustable.
- Backside with a pair of vertical cable management.
- Mounting rail with U mark.
- Efficient and solid cabinet connection.
- With earthing kits.
- Advanced lock.
- Optional plinth to meet under-base wiring, ventilation and rat-proof.
- Adjustable feet and heavy duty castors are available at the same time , static loading: 1000KG.
- Full range of optional accessories.

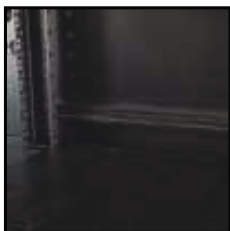

Frame with scale mark



Mounting rail with U mark

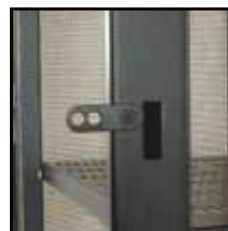

Connection Kits



Removable double-section side panel

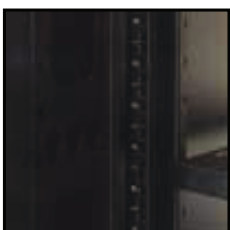

Backside with a pair of vertical cable management



Enhanced hinge



Curved perforated door



Steel casement door

**STRUCTURAL**

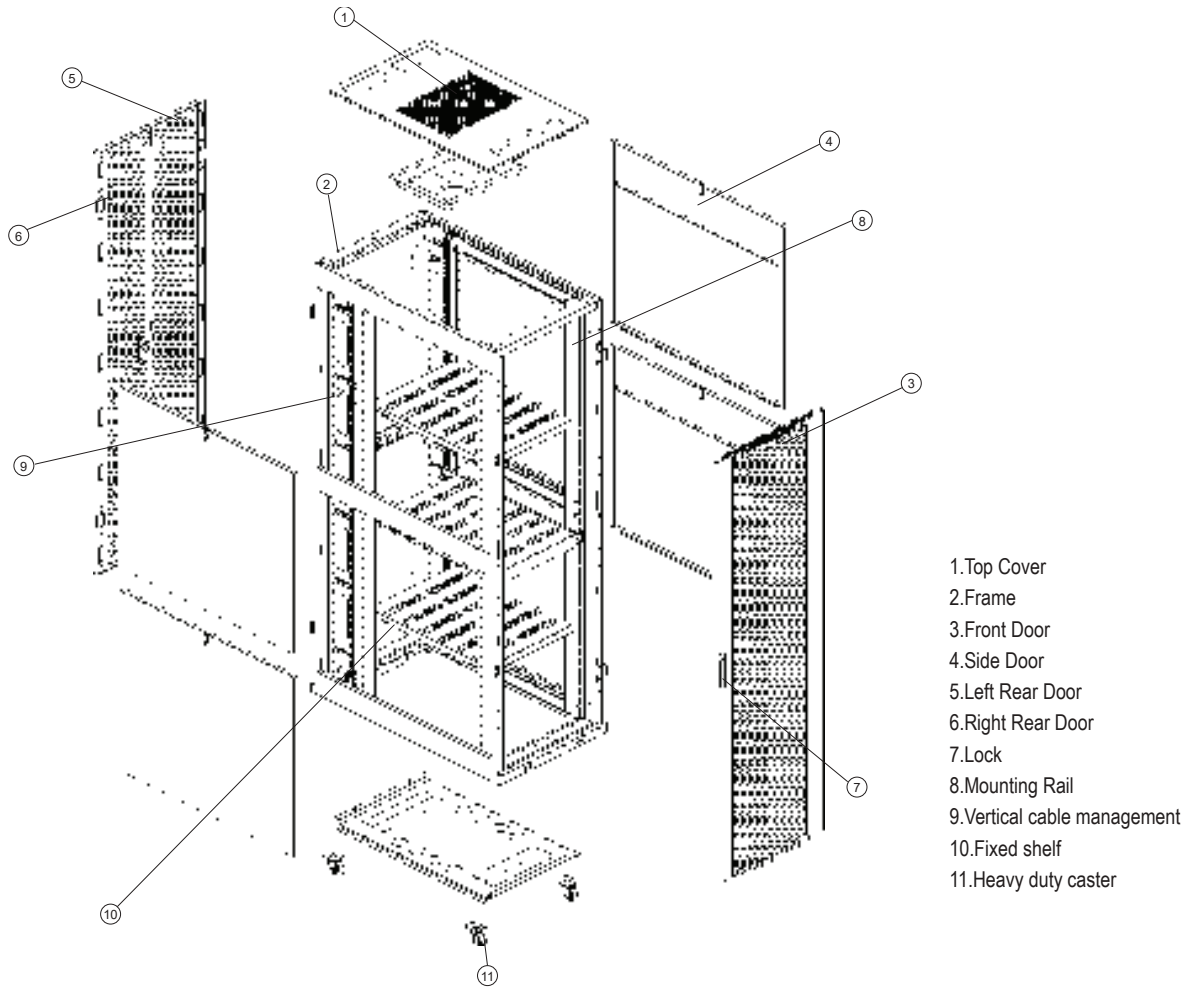

**ORDER INFOMATION**

PRODUCT	DESCRIPTION	PART NUMBER
36U	19" Internet Data Center, 36U Curved Perforated Door, Double Swing Door 600x600x179 (mm)	R-D36-6060-KLA
	19" Internet Data Center, 36U Curved Perforated Door, Double Swing Door 600x800x179 (mm)	R-D36-6080-KLA
	19" Internet Data Center, 36U Curved Perforated Door, Double Swing Door 600x1100x179 (mm)	R-D36-6011-KLA
	19" Internet Data Center, 36U Curved Perforated Door, Double Swing Door 800x800x179 (mm)	R-D36-8080-KLA
	19" Internet Data Center, 36U Curved Perforated Door, Double Swing Door 800x1100x179 (mm)	R-D36-8011-KLA
42U	19" Internet Data Center, 42U Curved Perforated Door, Double Swing Door 600x600x205 (mm)	R-D42-6060-KLA
	19" Internet Data Center, 42U Curved Perforated Door, Double Swing Door 600x800x205 (mm)	R-D42-6080-KLA
	19" Internet Data Center, 42U Curved Perforated Door, Double Swing Door 600x1100x205 (mm)	R-D42-6011-KLA
	19" Internet Data Center, 42U Curved Perforated Door, Double Swing Door 800x800x205 (mm)	R-D42-8080-KLA
	19" Internet Data Center, 42U Curved Perforated Door, Double Swing Door 800x1100x205 (mm)	R-D42-8011-KLA
4 Door 42U	19" Internet Data Center, 42U, 4 Door, Double Swing Door 800x1100x205 (mm)	R-D42-4D-8011-KLA