

SFP MODULE SYSTEM PRODUCTS

SFP Industrail Module Dual Fiber, 1.25Gbps 1310nm 10km



FEATURE

- Supports 1.25Gbps/1.0625Gbps bit rates
- Duplex LC connector
- Hot pluggable SFP footprint, Hot-swappable
- 1310nm FP laser transmitter and PIN photo-detector
- Applicable for 10km SMF connection
- Low power consumption, < 0.8W
- Digital Diagnostic Monitor Interface
- Compliant with SFP MSA and SFF-8472
- Very low EMI and excellent ESD protection
- Operating case temperature: Industrial:-40 to 85 °C



APPLICATIONS

- Gigabit Ethernet
- Fiber Channel
- Switch to Switch interface
- Switched backplane applications
- Router/Server interface
- Other optical transmission systems

OVERVIEW

MC-ISFP-LX-SM-0210 , SFP transceivers are high performance , cost effective modules supporting dual data-rate of 1.25Gbps/1.0625Gbps and 20km transmission distance with SMF.The transceiver consists of three sections: a FP laser transmitter, a PIN photodiode integrated with a trans-impedance preamplifier (TIA) and MCU control unit. All modules satisfy class I laser safety requirements.The transceivers are compatible with SFP Multi-Source Agreement (MSA) and SFF-8472. For further information, please refer to SFP MSA.

FUNCTIONAL DIAGRAM

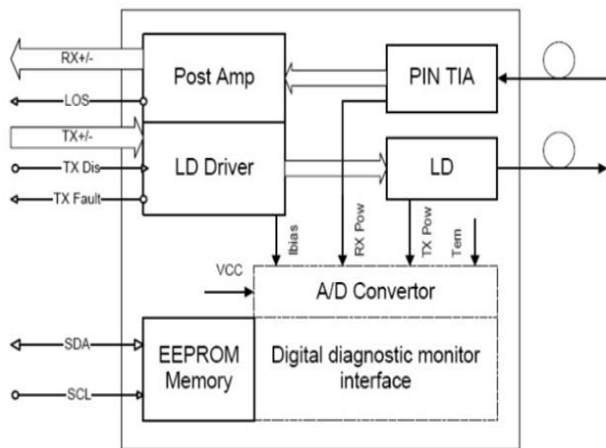

PACKAGE DIMENSIONS

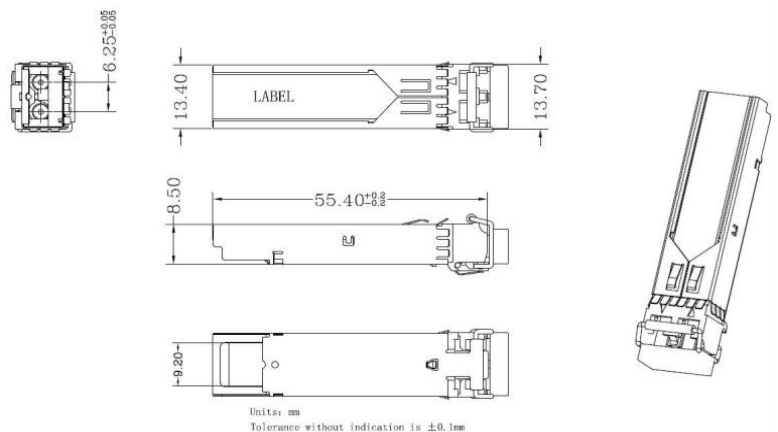

FOCOMM (THAILAND) CO., LTD

12 Soi Sukhaphiban 5 Soi 5 Yaek 3, Tha Raeng Subdistrict, Bang Khen District Bangkok 10220

Email : info@focomm-cabling.com www.focomm-cabling.com

ABSOLUTE MAXIMUM RATINGS

Parameter	Symbol	Min	Max	Unit
Supply Voltage	Vcc	-0.5	4.0	V
Storage Temperature	Ts	-40	+85	°C
Relative Humidity	RH	0	85	%

GENERAL OPERATING CHARACTERISTICS

Parameter	Symbol	Min	Typical	Max	Unit
Data Rate	DR	1.0625	1.25		Gb/s
Supply Voltage	Vcc	3.13	3.3	3.47	V
Supply Current	Icc,			220	mA
Operating Case Temp.	Tc	0		70	°C
	Tl	-40		+85	°C

ELECTRICAL CHARACTERISTICS

Parameter	Symbol	Min	Typical	Max	Unit
Transmitter					
Differential data input swing	VIN,PP	120		820	mVpp
Tx Disable Input-High	VIH	2.0		Vcc+0.3	V
Tx Disable Input-Low	VIL	0		0.8	V
Tx Fault Output-High	VOH	2.0		Vcc+0.3	V
Tx Fault Output-Low	VOL	0		0.5	V
Input differential impedance	Rin		100		Ω
Receiver					
Differential data output swing	Vout,pp	300	650	800	mVpp
Rx LOS Output-High	VROH	2.0		Vcc+0.3	V
Rx LOS Output-Low	VROL	0		0.8	V

OPTICAL CHARACTERISTICS

Parameter	Symbol	Min	Typical	Max	Unit
Transmitter					
Operating Wavelength	λ	1270	1310	1360	nm
Ave. output power (Enabled)	PAVE	-9		-3	dBm
Extinction Ratio	ER	9			dB
RMS spectral width	Δλ			0.65	nm
Rise/Fall time (20%~80%)	Tr/Tf	0		0.26	ns
Dispersion penalty	TDP			3.9	dB
Output Optical Eye	Compliant with IEEE802.3 z (class 1 user safety)				

Receiver

Operating Wavelength	λ	1260	1610	nm
Receiver Sensitivity	PSEN1		-22	dBm
Overload	PAVE	-3		dBm
LOS Assert	Pa	-35		dBm
LOS De-assert	Pd		-24	dBm
LOS Hysteresis	Pd-Pa	0.5		dB

DIGITAL DIAGNOSTIC SPECIFICATIONS

Parameter	Symbol	Units	Min	Max	Accuracy
Transceiver temperature	DTemp-E	°C	-45	+90	±5°C
Transceiver supply voltage	DVoltage	V	2.8	4.0	±3%
Transmitter bias current	DBias	mA	2	15	±10%
Transmitter output power	DTx-Power	dBm	-12	0	±3dB
Receiver average input power	DRx-Power	dBm	-25	0	±3dB

ORDER INFORMATION

PRODUCT	PART NUMBER
SFP Industrail Module Dual Fiber, 1.25Gbps 850nm 550m	MC-ISFP-SX-MM-0205
SFP Industrail Module Dual Fiber, 1.25Gbps 1310nm 10km	MC-ISFP-LX-SM-0210
SFP Industrail Module Dual Fiber, 1.25Gbps 1310nm 20Km	MC-ISFP-LX-SM-0220
SFP Industrail Module Dual Fiber, 1.25Gbps 1310nm 40km	MC-ISFP-LX-SM-0240
SFP Industrail Module Dual Fiber, 1.25Gbps 1550nm 80km	MC-ISFP-ZX-SM-0280
SFP Industrail Module Dual Fiber, 1.25Gbps 1550nm 120km	MC-ISFP-ZX-SM-02120