

# RACK AND CABINET PRODUCT

SERVER/NETWORK CABINET SERIES



## FEATURE

- Exquisite design with precise craftsmanship
  - Good compatibility, adapt to more servers. Perfect ventilation
  - Vented front door and rear door enable ventilation and reliable operation
  - The top and bottom wiring channel can be closed and adjusted.
  - Optional plinth to meet under base wiring, ventilation and rat-proof
  - Rack's side panel can be easily assembled.
  - Efficient and solid cabinet connection
  - Adjustable feet and heavy duty castors are available at the same time , static loading: 1,600kg.(with adjustable feet).
  - Advanced lock, Available in black
  - Surface finish: degreasing, pickling, phosphating, power coating.
  - Height, width, and depth selectable, full range of optional accessories.
  - The cabinet has a key to lock the cabinet door to increase locking security.
- important
- Rubber proof 3 fin
  - Support Power Bar Universal 6/12/20



## MATERIALS

Electro-galvanized steel sheet Cold-rolled steel sheet. Thickness for frame 1.2mm, mounting rail 2.0mm(1.5mm for 600mm depth cabinet), fixed shelf 1.2mm , side panel 1.2mm. Thickness for tempered glass Smoke gray 5mm.

## APPLICATION

Widely used in network system, educational system, broadcasting system and telecommunication system. Suitable for placing server computer and precision electronic equipment.

Adopted by the professional servers' network providers as IBM, SUN, HP, COMPAQ, DELL etc.

## STANDARD

Comply with ANSI/EIA-310D-1992, BS 5954:Part 2, IEC297-1/2, DIN41491; PART1, IEC60297-1, IEC60297-2, DIN41494; PART7, GB/T3047.2-92 standard. Compatible with metric ETSI and 19 inch international standard.



Crescent lock



asily assembled side panel



Symmetrical frame

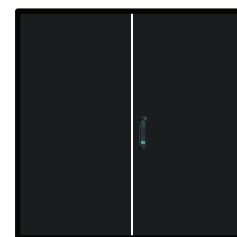

double swing steel door



Cooling fan



Bottom plate



Mounting rail with U mark

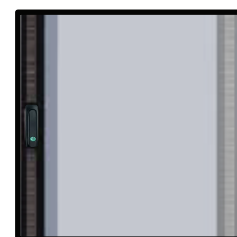

smoky-gray glass door

## ASSEMBLING DRAF

Package a:  
(top cover and bottom plate,  
mounting angle, fan tray, shelf, accessories bag)

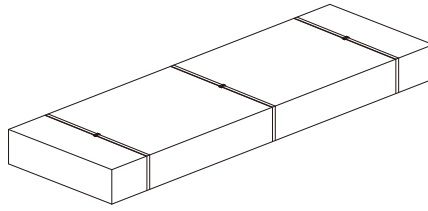
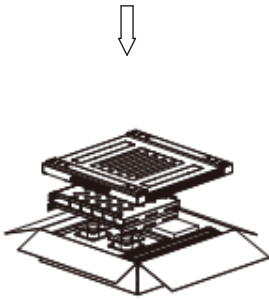
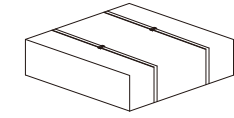

Package b:  
(side panel, mounting rail, rear door, front door)

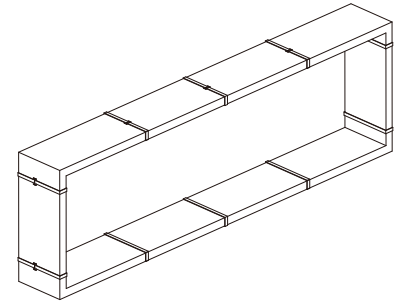
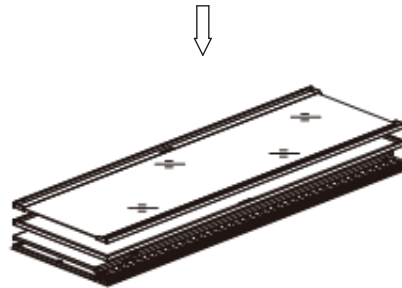

Package c: (frame)

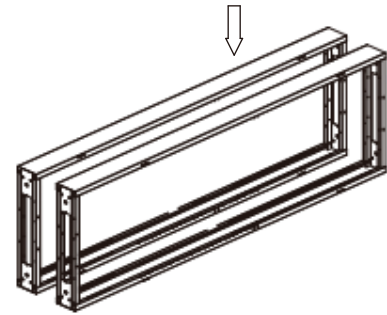

### COLOR

BB =  Black(RAL9004)

BG =  Gray(RAL7044)

## ORDER INFOMATION

PRODUCT	DESCRIPTION	PART NUMBER
15U	19" Network Rack Cabinet, 15U Glass Door, Double Swing Steel Door, 600x600x850 (mm)	R-N15-6060-BF-BB/BG
27U	19" Network Rack Cabinet, 27U Glass Door, Double Swing Steel Door 600x600x1390 (mm)	R-N27-6060-BF-BB/BG
	19" Network Rack Cabinet, 27U Glass Door, Double Swing Steel Door 600x800x1390 (mm)	R-N27-6080-BF-BB/BG
	19" Network Rack Cabinet, 27U Glass Door, Double Swing Steel Door 600x1000x1390 (mm)	R-N27-6010-BF-BB/BG
36U	19" Network Rack Cabinet, 36U Glass Door, Double Swing Steel Door 600x600x1790 (mm)	R-N36-6060-BF-BB/BG
	19" Network Rack Cabinet, 36U Glass Door, Double Swing Steel Door 600x800x1790 (mm)	R-N36-6080-BF-BB/BG
	19" Network Rack Cabinet, 36U Glass Door, Double Swing Steel Door 600x1100x1790 (mm)	R-N36-6011-BF-BB/BG
	19" Network Rack Cabinet, 36U Glass Door, Double Swing Steel Door 800x800x1790 (mm)	R-N36-8080-BF-BB/BG
	19" Network Rack Cabinet, 36U Glass Door, Double Swing Steel Door 800x1100x1790 (mm)	R-N36-8011-BF-BB/BG
42U	19" Network Rack Cabinet, 42U Glass Door, Double Swing Steel Door 600x600x2050 (mm)	R-N42-6060-BF-BB/BG
	19" Network Rack Cabinet, 42U Glass Door, Double Swing Steel Door 600x800x2050 (mm)	R-N42-6080-BF-BB/BG
	19" Network Rack Cabinet, 42U Glass Door, Double Swing Steel Door 600x1100x2050 (mm)	R-N42-6011-BF-BB/BG
	19" Network Rack Cabinet, 42U Glass Door, Double Swing Steel Door 800x800x2050 (mm)	R-N42-8080-BF-BB/BG
	19" Network Rack Cabinet, 42U Glass Door, Double Swing Steel Door 800x1100x2050 (mm)	R-N42-8011-BF-BB/BG